

Position Transducers up to 3000 mm

TLH Series

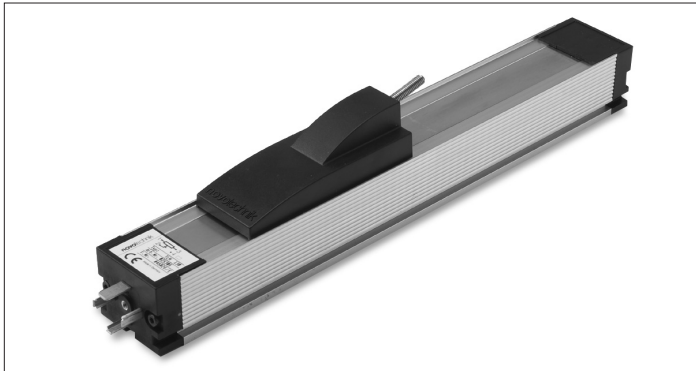

Special features

- rodless design
- very high operating speed
- ball coupling avoids side loads
- long life > 100 x 10⁶ movements
- outstanding linearity
- high resolution – better than 0.01 mm
- real-time capability
- connector to DIN 43650 (hydraulic connector)
- protection class IP 54

TLH transducers are designed for the direct, accurate measurement of displacement or length in control, regulation and measuring applications. The rodless design allows the actuator to be driven from the side, along the unit length, this allows the total length of the transducer to be shorter and permits stroke lengths up to 4000 mm.

The simplicity of the measuring technique – both passive and absolute – ensures that the transducer is immune to external electrical interference, and that it does not require any built-in power supply to maintain positional information in the event of power failure. Like other potentiometrics, it is a real-time sensor.

A magnetically restrained stainless steel band completely covers the opening through which the actuator operates. The ball coupling is of a new design which prevents forces, generated through parallel or angular offsets, from being transmitted to bearing surfaces. Due to the design and the selected materials the temperature coefficient of the transducer is extremely small. Careful attention to detail and choice of materials has resulted in a transducer with an extremely low temperature drift. The robust design ensures reliable operation even under harsh environmental conditions such as vibration or temperature changes.

The TLH series is designed for clamp mounting. The use of clamps simplifies installation and adjustment.

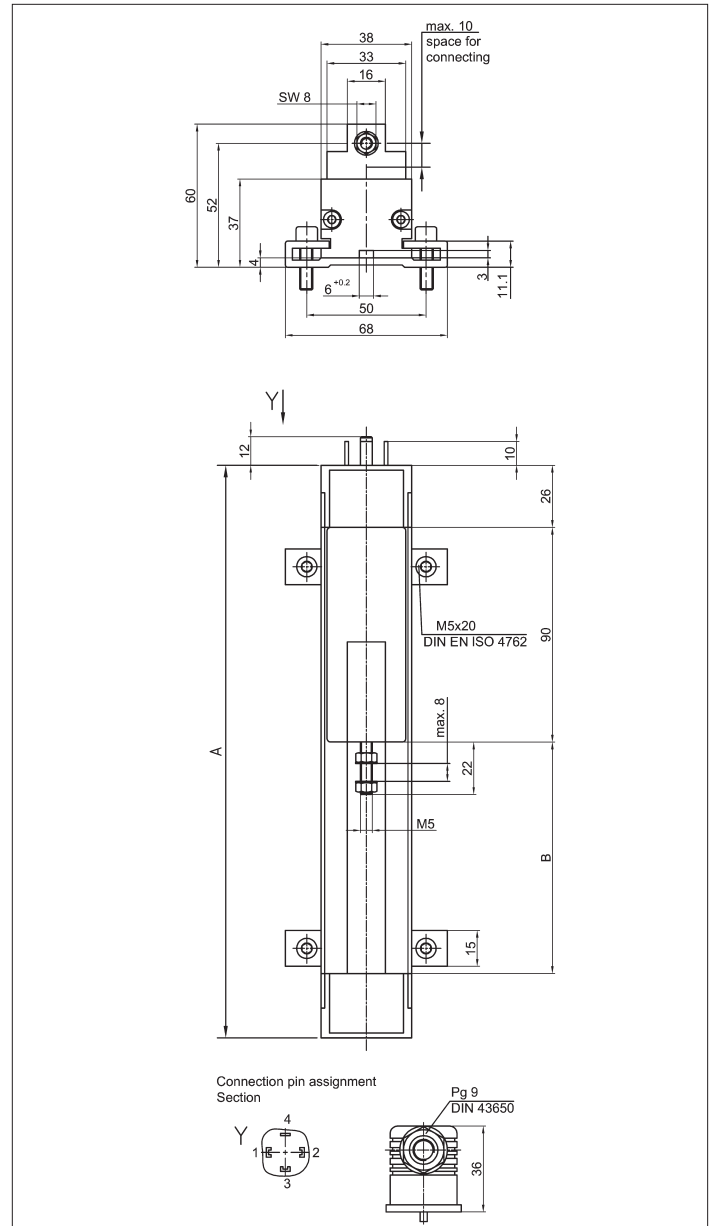
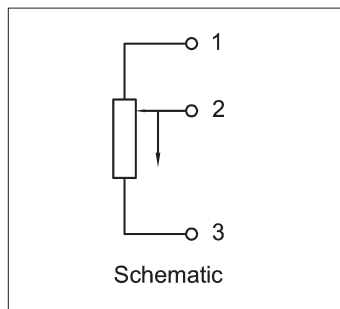

Description

Housing	aluminum, anodized
Fixings	adjustable clamps
Sliding parts	aluminum with plastic inserts
Coupling	ball coupling, incorporating a hardened ball, with spring and hardened plate.
Resistance element	conductive plastic
Wiper assembly	precious metal multi-finger wiper, elastomer-damped
Electrical connections	4-pole socket to DIN 43650 (hydraulic connector)

Type designations	TLH 100	TLH 130	TLH 150	TLH 225	TLH 300	TLH 360	TLH 450	TLH 500	TLH 600	TLH 750	TLH 900	TLH 1000	TLH 1250	TLH 1500	TLH 1750	TLH 2000	TLH 2250	TLH 2500	TLH 2750	TLH 3000	
Electrical Data																					
Defined electrical range	100	130	150	225	300	360	450	500	600	750	900	1000	1250	1500	1750	2000	2250	2500	2750	3000	mm
Electrical stroke	102	132	152	228	304	366	457	508	610	762	914	1016	1270	1520	1770	2020	2270	2520	2770	3020	mm
Nominal resistance	3	3	5	5	5	5	5	5	5	10	10	10	10	20	20	20	20	20	20	20	kΩ
Resistance tolerance	20																				±%
Independent linearity	0.1	0.09	0.08	0.07	0.06	0.05	0.05	0.05	0.05	0.04	0.04	0.04	0.03	0.03	0.03	0.02	0.02	0.02	0.02	0.02	±%
Repeatability	0.01																				mm
Recommended operating wiper current	≤ 1																				μA
Max. wiper current in case of malfunction	10																				mA
Max. permissible applied voltage	42																				V
Effective temperature coefficient of the output-to-applied voltage ratio	5 (typical)																				ppm/K
Insulation resistance (500 VDC, 1 bar, 2 s)	≥ 10																				MΩ
Dielectric strength (50 Hz, 2 s, 1 bar, 500 VAC)	≤ 100																				μA
Mechanical Data																					
Body length (dimension A)	250	280	300	376	452	514	605	656	758	910	1062	1164	1418	1668	1918	2168	2418	2668	2918	3168	±2 mm
Mechanical stroke (dimension B)	108	138	158	234	310	372	463	514	616	768	920	1022	1276	1526	1776	2026	2276	2526	2776	3026	±2 mm
Total weight	440	480	500	620	730	820	950	1020	1170	1390	1600	1750	2110	2470	2830	3200	3560	3920	4280	4650	g
Weight of sliding part	45																				g
Permitted movement of ball coupling	±1° angular offset, ±1.5 mm parallel offset																				
Operating force (horizontal)	0.4																				N
vertical	1.1																				N

Environmental Data		
Temperature range	-30...+100	°C
Vibration	5...2000 A _{max} = 0.75 a _{max} = 20	Hz mm g
Shock	50 11	g ms
Life	> 100 x 10 ⁶	movem.
Operating speed	10	m/s max.
Operating acceleration	200 (20 g)	m/s ² max.
Protection class	IP 40 (DIN 400 50 / IEC 529) IP 54 (DIN 400 50 / IEC 529) mounted "upside-down"	

Included in delivery
fixing clamps Z 43,
1 plug connector
GDM 3009,
1 seal GDM 3-16

Recommended accessories
Process-controlled indicators
MAP...with display,
Signal conditioner MUW.../MUK
...for standardized output signals

Subject to changes
© November 2004
Novotechnik U.S., Inc. All rights reserved.

Order designations	
Type	Art. no.
TLH 100	025304
TLH 130	025305
TLH 150	025306
TLH 225	025309
TLH 300	025312
TLH 360	025314
TLH 450	025318
TLH 500	025320
TLH 600	025324
TLH 750	025330
TLH 900	025336
TLH 1000	025340
TLH 1250	025350
TLH 1500	025360
TLH 1750	025370
TLH 2000	025380
TLH 2250	025381
TLH 2500	025383
TLH 2750	025384
TLH 3000	025385

Other lengths on request

Important

All values given for this series – including linearity, lifetime, micro-linearity, resistance to external disturbances and temperature coefficient in voltage dividing mode – are quoted for the device operating with the wiper voltage driving an operational amplifier working as a voltage follower where virtually no load is applied to the wiper (I_e ≤ 1 μA).

Mounting instructions

It is recommended that the transducer be mounted "upside-down". Only when orientated in this manner, the drop-off-edges which are parallel to the actuator slot work effectively and a build-up of dirt on the sealing band be prevented when the device is used in a dusty environment.