

Position Transducers up to 750 mm

LWG Series



Special features

- twin-bearing actuating rod
- mountable over backlash-free pivot heads with a large angle of free movement (up to $\pm 12.5^\circ$)
- outstanding linearity
- resolution better than 0.01 mm
- life (depending on application) up to 50 million movements
- protection class IP 65
- M12 Connector

The LWG series was designed for a wide range of demanding applications in the mechanical, vehicle, automation and robotics industries. Outstanding linearity and accurate measurement are achieved with a resistance element made of conductive plastic welded to a glass-fiber reinforced substrate.

The wiper system is mounted on the actuating rod and coupled free-of-backlash for a long life and trouble-free operation.

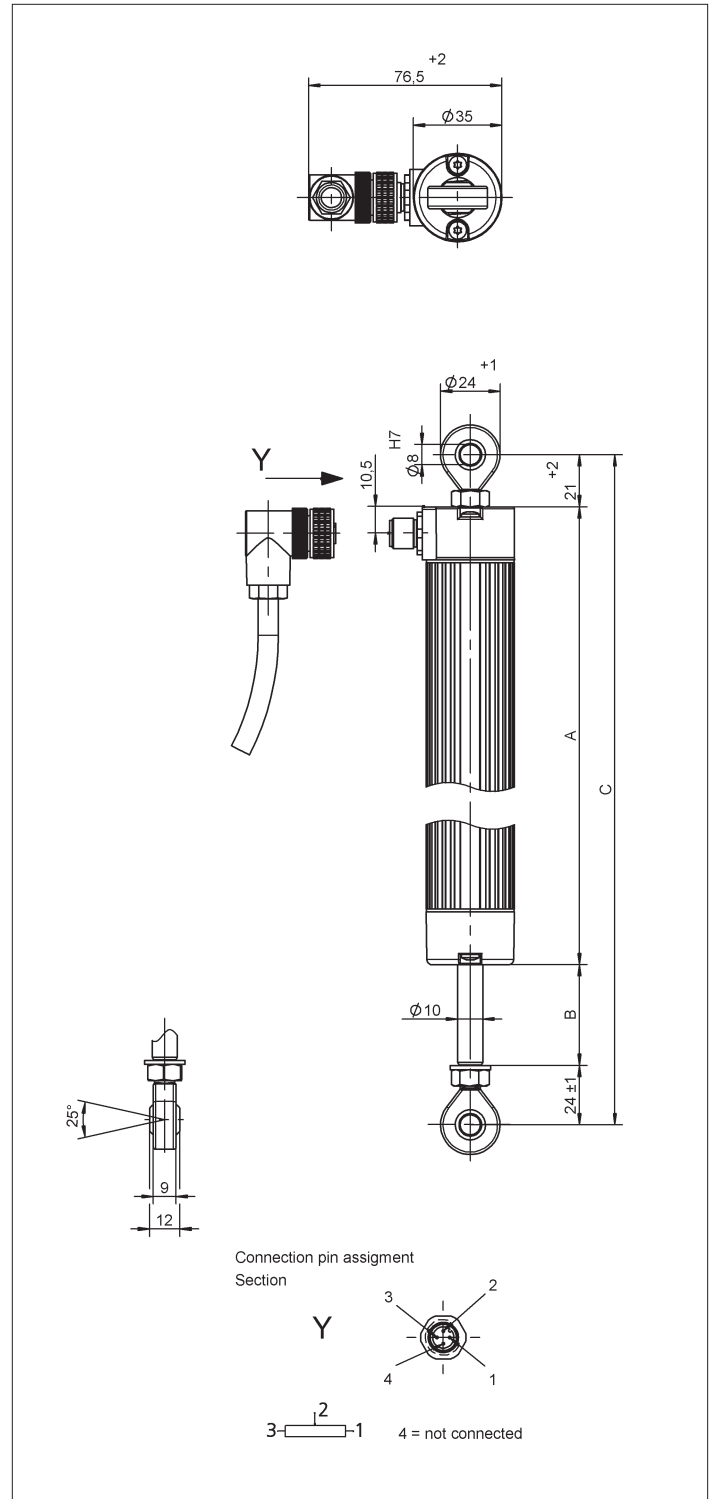
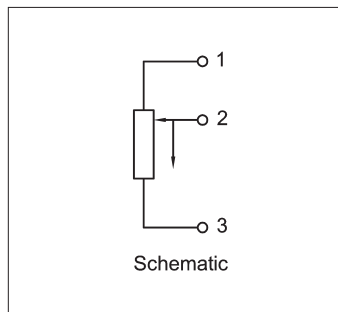

Novotechnik U.S., Inc.155 Northboro Road
Southborough, MA 01772

Phone: 508-485-2244

Fax: 508-485-2430

Email: info@novotechnik.com

Description		Environmental Data		
Housing	aluminum, anodized	Temperature range	-30...+100	°C
Fixings	see drawing	Vibration	5...2000 $A_{max} = 0.75$ $a_{max} = 20$	Hz mm g
Actuator	stainless steel, rotatable	Shock	50 11	g ms
Bearings	sleeve bearing	Life	50 x 10 ⁶ (typical)	movem.
Resistance element	conductive plastic	Operating speed	5	m/s max.
Wiper assembly	precious metal multi-finger wiper, elastomer damped	Protection class	IP 65 (DIN 400 50 / IEC 529)	
Electrical connections	4-pin M12 connector			

Type designations	LWG 75	LWG 100	LWG 150	LWG 225	LWG 300	LWG 360	LWG 450	LWG 500	LWG 600	LWG 750	
Electrical Data											
Defined electrical range	75	100	150	225	300	360	450	500	600	750	mm
Electrical stroke	76	102	152	228	304	366	457	508	610	762	mm
Nominal resistance	3	3	5	5	5	5	5	5	5	10	kΩ
Resistance tolerance	20										±%
Independent linearity	0.1	0.1	0.08	0.07	0.06	0.05	0.05	0.05	0.05	0.04	%
Repeatability	< 0.01										mm
Recommended operating wiper current	≤ 1										μA
Max. wiper current in case of malfunction	10										mA
Max. permissible applied voltage	42										V
Effective temperature coefficient of the output-to-applied voltage ratio	typical 5										ppm/K
Insulation resistance (500 VDC, 1 bar, 2 s)	≥ 10										MΩ
Dielectric strength (50 Hz, 2 s, 1 bar, 500 VAC)	≤ 100										μA
Mechanical Data											
Body length (dimension A)	201	227	277	354	430	505	619	684	810	994	±2 mm
Mechanical stroke (dimension B)	79	105	155	231	307	368	460	510	612	764	±2 mm
Minimum distance between pivot heads (dimension C)	247	273	323	400	476	551	665	730	856	1040	mm
Operating force											
horizontal	3.6	3.7	4.0	4.5	4.9	5.2	5.7	6	6.6	7.5	N
vertical	7.4	7.6	8.0	8.7	9.3	9.8	10.6	11	11.9	13.2	N

Order designations	
Type	Art. no.
LWG 75	026103
LWG 100	026104
LWG 150	026106
LWG 225	026109
LWG 300	026112
LWG 360	026114
LWG 450	026118
LWG 500	026120
LWG 600	026124
LWG 750	026130
Other lengths on request	

Recommended accessories

Process-controlled indicators
MAP...with display,
Signal conditioner MUP.../MUK...
for standardized output signals

Important

All values given for this series – including linearity, lifetime, micro-linearity, resistance to external disturbances and temperature coefficient in voltage dividing mode – are quoted for the device operating with the wiper voltage driving an operational amplifier working as a voltage follower where virtually no load is applied to the wiper ($I_e \leq 1 \mu A$).

Subject to changes

© November 2004

Novotechnik U.S., Inc. All rights reserved.